

Automatic blow out device ADB 2000

Technical Documentation



Manufacturer:

SECURITON GmbH
Von-Drais-Straße 33
77855 Achern, Deutschland
www.securiton.de

The product (hardware, software and technical documentation) is subject to the copyright of the manufacturer. Any prohibited modification, misuse, copying or prohibited sale of this product represents a violation of the copyright and will be legally prosecuted.

Copyright by SECURITON GmbH

Validity



NOTICE

This document is valid only for the product described in this chapter and may be changed or withdrawn without prior notice. The validity of the statements made in this document applies until the statements are revised by a new edition of the document (TD 004 054 with new index). The user of this document is responsible for staying up to date with its current status through the editor/publisher. We accept no responsibility for claims against any incorrect statements in this document that were unknown to the publisher at the time of publication. Handwritten changes and additions are invalid.

Foreign language documents as listed in this document are always released or changed at the same time as the German edition. If there are inconsistencies between the foreign language document and the German document, the German text is binding.

Some words in this document are highlighted in **blue**. These terms and designations are the same in all languages and are not translated. Users are encouraged to contact the editor/publisher if there are statements which are unintelligible, misleading, incorrect or which contain errors.

This document is intended for trained specialists for mounting, installation, commissioning and maintenance of the product.



NOTICE

The following document is applicable to the automatic blow out device ADB 2000 with the following production version and firmware version:

Production version

from 010218

Firmware version

from V090400

The validity of older production versions and firmware versions is guaranteed, with the exception of the new functionalities described in this edition. Additional information about the new functionalities can be found in the document history.

Document history

First edition Date 01.02.2018

Index "a" Date 01.09.2018

Most important changes compared with previous issue:

Section / Fig.	New (n) / changed (c) / deleted (d)		What / Reason
Page 3	n	Firmware version	Edition
All	c	Documentation page format adjusted	New document format
8.2	d	Function "Kontakt WE"	Correction
13	c	Montage Guidelines	Correction sequence
14	c	Article numbers	Correction

Content

1	General	7
1.1.1	Notice and warning symbols	7
1.1.2	Safety information	8
1.1.4	Disposal	9
1.1	Product identification	9
1.2	Guarantee	9
1.3	Product changes	9
2	Application area	10
3	Construction	11
4	Function	12
5	Functional description	13
6	Mounting / Commissioning	16
6.1	Drilling plan for housing	17
6.2	Description of connections	17
7	Mounting guidelines	18
8	Compressed air supply	19
9	Fault transmission to CIE	20
10	Configuration automatic blow out device	21
10.1	""External input" function	22
10.2	"WE contact" function	22
11	Maintenance / Service	23
12	Technical data	24
13	Technical Data Compressor / Pressurized Air	24
14	Article numbers	25
15	List of figures	27

1 General

Provided the product is deployed by trained and qualified personnel in accordance with this document, and provided the safety symbols all notices are observed, there is no danger to persons or property under normal conditions and when used properly. The product fulfils the requirements ensuring personal safety and environmental protection during operation. National and state-specific laws, regulations and directives must be observed and adhered to in all cases.

Observe these danger notices. They help prevent accidents and damage.

1.1.1 Notice and warning symbols

The following notice and warning symbols are used to draw attention to hazards and special properties.



DANGER

The product may represent an immediate danger with a high level of risk to persons if the notice is not duly observed. If the danger is not avoided, death or serious injury may result.



WARNING

The product may represent a possibly imminent danger with a medium level of risk to persons if the notice is not duly observed. If the danger is not avoided, death or serious injury may result.



CAUTION

The product may represent a possibly imminent danger with a low level of risk to persons if the notice is not duly observed. If the danger is not avoided, a minor injury may result.



NOTICE

If this notice is not observed, the product may malfunction, may cause property damage, or may be harmful to the environment.

1.1.2 Safety information



ELECTRICAL SHOCK

The product is operated with electrical current. In the event of incorrect mounting, installation, commissioning or maintenance, an electrical shock may be life-threatening or there is the danger of serious injury. It is imperative that the safety information is observed.



READ THE USER INSTRUCTIONS



To ensure safe and proper use, it is absolutely necessary to read the instructions and other documentation accompanying the product before use and to keep such documentation at hand for later reference. It is imperative that the danger information in particular is observed.



ELECTROSTATIC DISCHARGE



The product includes electronic components that are sensitive to electrostatic discharge (ESD). Contact with persons or objects can cause an electrostatic discharge that damages or destroys the product. ESD bands for preventing electrostatic discharge are used for grounding persons and for equipotential bonding.

1.1.4 Disposal



Electrical and electronic devices and batteries

It is not permitted to dispose of electrical and electronic devices or batteries in the domestic rubbish. As the end user you are legally obliged to return them. Used electrical and electronic devices as well as batteries can be returned to the seller or taken to a designated recycling centre (e.g. a community collection point or dealer) at no cost.



RECYCLING

The product and its components including their packaging consist of recyclable material and can be disposed of for recycling purposes as described in this document.

1.1 Product identification



NOTICE

The rating plates, type designations and/or identifications on devices and printed circuit boards must not be removed, written over or defaced in any way.

1.2 Guarantee



NOTICE

The product may be operated only with the hardware, software and commissioning media designated and delivered by the manufacturer. Any unauthorised intervention in the hardware and/or software or the use of non-system products is prohibited and may result in malfunctions and/or damage to the product. If this is not observed, all guarantee and warranty rights with respect to the manufacturer of the product will become null and void. Further, non-observance of the user instructions as well as improper maintenance and repair work void the guarantee and product liability.

1.3 Product changes



NOTICE

It is always recommended to use the latest version of the product software. A change to hardware or software of a product made by the manufacturer, is not a right to an update for existing products.

2 Application area

The automatic blow out device ADB 2000 is used as an accessory part for the aspirating smoke detector SecuriRAS® in areas with high levels of dust and dirt. With the blow out device, the aspirating smoke detectors sampling pipes are automatically blown through and cleaned to prevent fault messages due to contaminated suction openings and false alarms. The lifespan of the smoke sensor in the aspirating smoke detector is likewise increased considerably.

When using the automatic blow out device ADB 2000, a combination with the accessory components extra-large filter box and dust retaining box (cyclone principle) is ***generally*** recommended.

3 Construction

The automatic blow out device ADB 2000 is integrated directly into the sampling pipe(s) of the aspirating smoke detector. For connection to the sampling pipe, corresponding screw connections with a diameter $d=25\text{mm}$ are present on the automatic blow out device ADB 2000. A compressed air supply with a *constant pressure of at least 4 bar* should be provided on site which can be adapted without problem to the blow out device. If the compressed air fails, this is relayed to the higher-level control and indicating equipment as a fault message by the automatic blow out device ADB 2000. The timeframe for troubleshooting can, however, be freely programmed using the DIL switch (see chapter 10). In case of appropriate programming, *no* fault message is triggered at the automatic air blow-out ADB 2000 even in the event of the compressed air being switched off at weekends or on holidays. Proper operation is thus ensured upon restarting the compressed air system.

4 Function

The air polluted with dust and dirt particles is also inevitably aspirated by the aspirating smoke detector. This has the result that the dust particles adhere to the sampling pipe and the suction openings and so cause dirt to build up here. The airflow monitoring of the aspirating smoke detector **must** detect any such blockage of the suction openings conforming to standards and report it as a fault message to the higher-level control and indicating equipment.

In order to prevent a fault message for the aspirating smoke detector caused by contamination, the automatic blow out device ADB 2000 is used in these fields of application. Blowing through the sampling pipe may optionally be carried out automatically at various intervals (programming by "DIL switch") or manually at any point in time.

Advantages of the automatic blow out device ADB 2000

- Prevention of fault messages caused by contaminated suction openings
- Lengthening of lifespan of smoke detectors / smoke sensors
- Prevention or substantial reduction of false alarms
- Fault message in the case of compressed air failure (detection period can be freely programmed)
- applicable for all aspirating smoke detectors
- subsequent installation possible at any time
- low installation costs
- Maintenance friendly

5 Functional description

There are various options for starting the blow-out process of the ADB 2000.

- Press "Start" (1x) on the mainboard BMB 2000 → Start of blow-out process at sampling pipe I
- Press "Start" (2x) on the mainboard BMB 2000 → Start of blow-out process at sampling pipe II
- Manual running of blow-out procedure due to stimulus on the contact "far"
- Automatic running of the blow-out procedure at different time intervals set by DIL switches (switch 7 to OFF).

Once the supply voltage is applied, the "fault" relay energises into hibernation mode. The fault delay is signalled by the flashing yellow LED. After the set delay time has expired, the fault relay de-energises and the yellow LED is lit statically (status display of fault LED → see chapter 9). The fault relay is to be connected to the higher-level control and indicating equipment.

- Start of the blow-out process at sampling pipe I
(Requirement: Limit switch 2 at sampling pipe I, limit switch 4 at sampling pipe II as well as limit switch WE are activated)
 - Connection between aspirating smoke detector and sampling pipe is interrupted
 - (relay "ASD-ZU" is energising)
 - Connection between sampling pipe and compressed air connection is established
 - Relay "ASD-AUF" energises (approx. 2 seconds later)
 - Limit switch 1 → ON
 - Relay "ZL-ZU" energises (approx. 2 seconds later)
 - Relay "ZL-AUF" energises (approx. 2 seconds later).
 - Limit switch 2 → OFF
 - Blow-out process is carried out
 - Relay "ZL-AUF" remains energised for **10 or 30 seconds** depending on the setting
 - Connection between sampling pipe and compressed air connection is established
 - Relay "ZL-AUF" de-energises after 10 / 30 seconds
 - Relay "ZL-ZU" de-energises (approx. 2 seconds later)
 - Limit switch 2 → ON
 - Connection between aspirating smoke detector and sampling pipe is restored
 - Relay "ASD-ZU" de-energises (approx. 10 seconds later)
 - Relay "ASD-AUF" de-energises (approx. 2 seconds later)
 - Limit switch 1 → OFF
 - End of the blow-out process at sampling pipe I
 - After a set time (DIL switch), the blow-out process starts for sampling pipe II

The corresponding state of the relay is displayed using a green LED (LED lights up if the relay is energised). If this process does not end properly after approx. 150 seconds, the "fault" relay de-energises and consequently signals a functional error to the higher-level control and indicating equipment.

If the aspirating smoke detectors SecuriRAS® are used, the airflow monitoring delay time must be adjusted to the ambient conditions. To ensure permanent function of the aspirating smoke detector, the following settings are recommended:

- Sensitivity of airflow monitoring: +20% (break) / -50% (contamination)
- Airflow monitoring delay time: 10 minutes (at least)

For setting of this airflow delay, the technical documentations of the respective aspirating smoke detector type SecuriRAS® are to be observed.

Functional description

Course of the blow-out process at sampling pipe I:

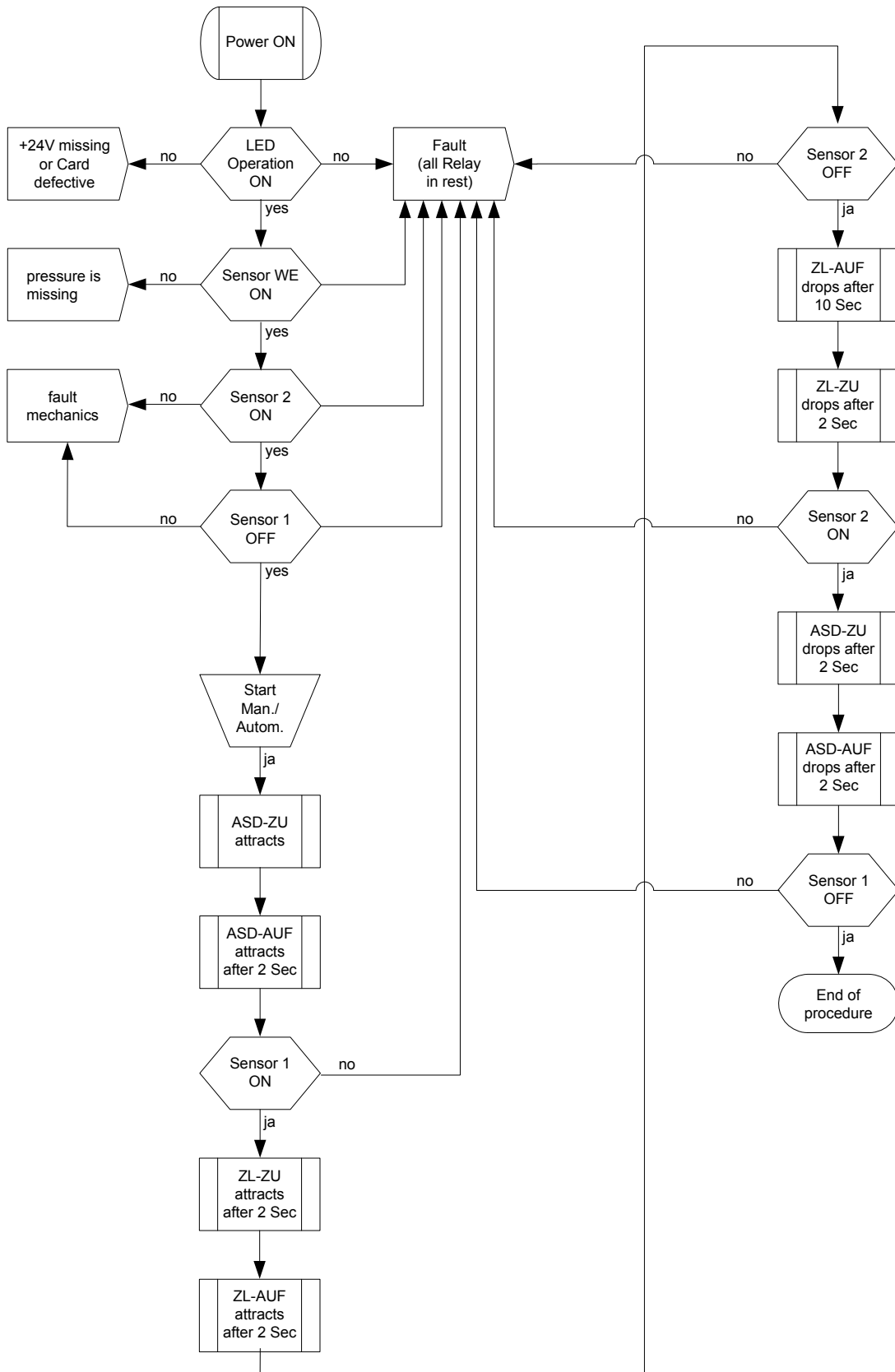

Fig. 1 Functional sequence, sampling pipe I

Course of the blow-out process at sampling pipe II:

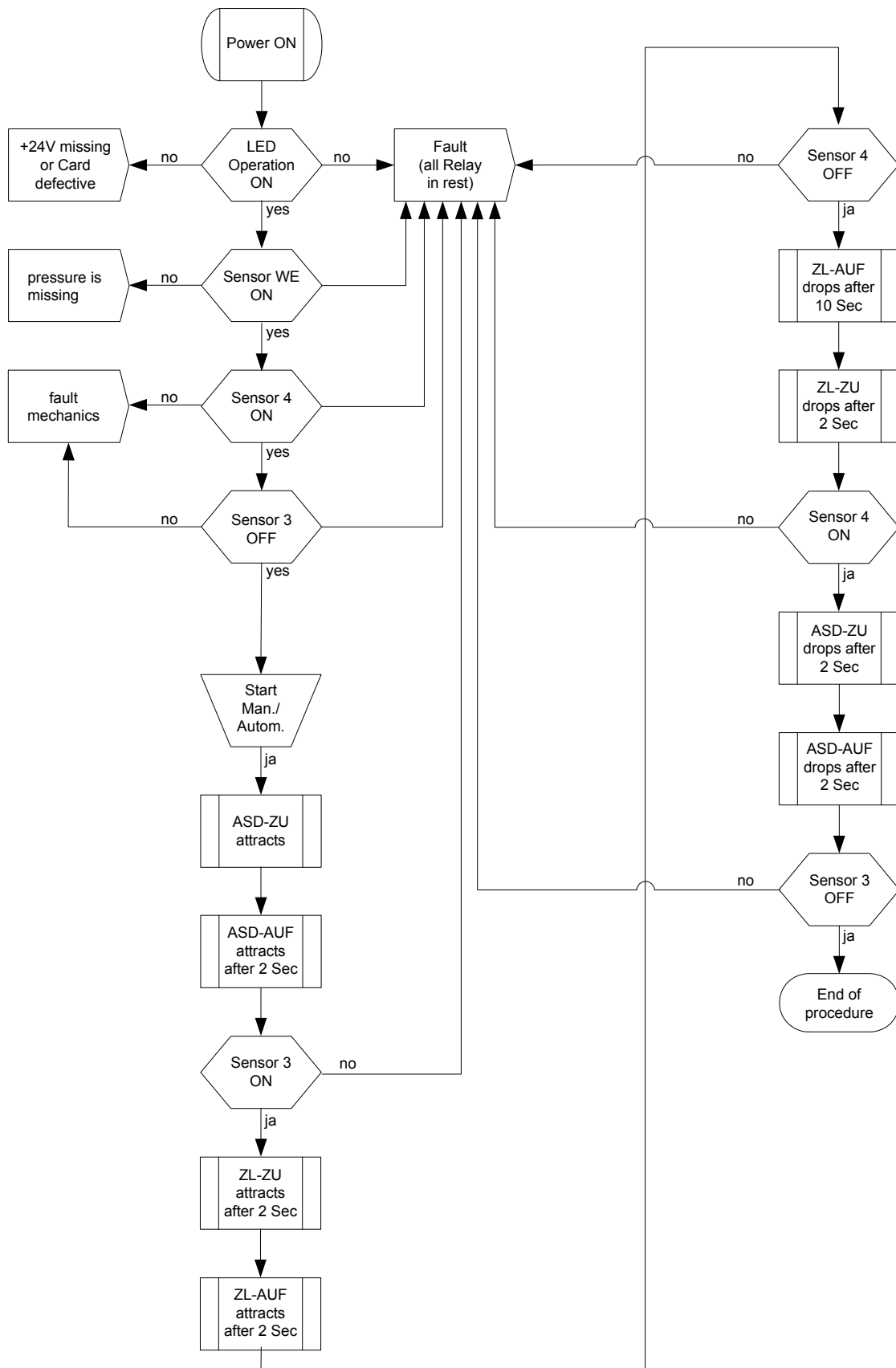

Fig. 2 Functional sequence, sampling pipe II

6 Mounting / Commissioning



CAUTION

Work on the automatic blow out device ADB 2000 may only be carried out in a depressurised state!

The automatic blow out device ADB 2000 is assembled directly beside the aspirating smoke detector.

Generally, use in combination with the extra large filter box and the dust retaining box (cyclone principle) is recommended. Installation should also be carried out in accordance with the mounting guidelines (see chapter 7).

An external power supply (15-30 VDC) is required for operating the automatic blow out device in accordance with the European product standard EN 54 - part 4. An emergency power supply is ensured in the event of a power failure.



NOTICE

The supply voltage must not be tapped directly from the aspirating smoke detector. A separate line for the power supply must be laid!

The sampling pipe of the aspirating smoke detector should be connected to the automatic blow out device ADB 2000 in accordance with the mounting guidelines (chapter 7) and attached to the intended adhesive properly. The splice should be treated in advance with the special cleaning agent.

The fault relay of ADB 2000 should be connected to the higher-level control and indicating equipment so that a fault transmission from this accessory component is also guaranteed. The compressed air provided by the building site is plugged into the automatic blow out device using the standard compressed air supply (see chapter 8).

The programming of the blow-out cycles should be made using the "DIL switches" located on the mainboard ADB 2000. The duration of the blow-out process is either **10 or 30 seconds** depending on the setting.

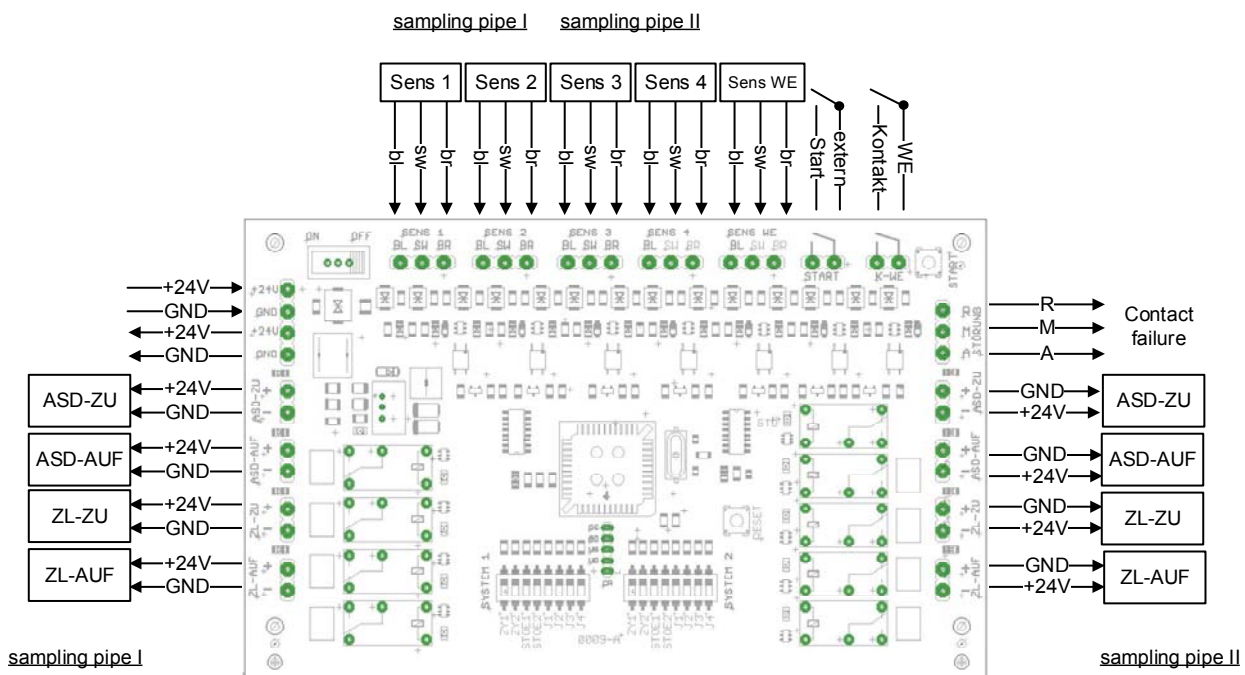

Fig. 3 Mainboard BMB 2000

6.1 Drilling plan for housing

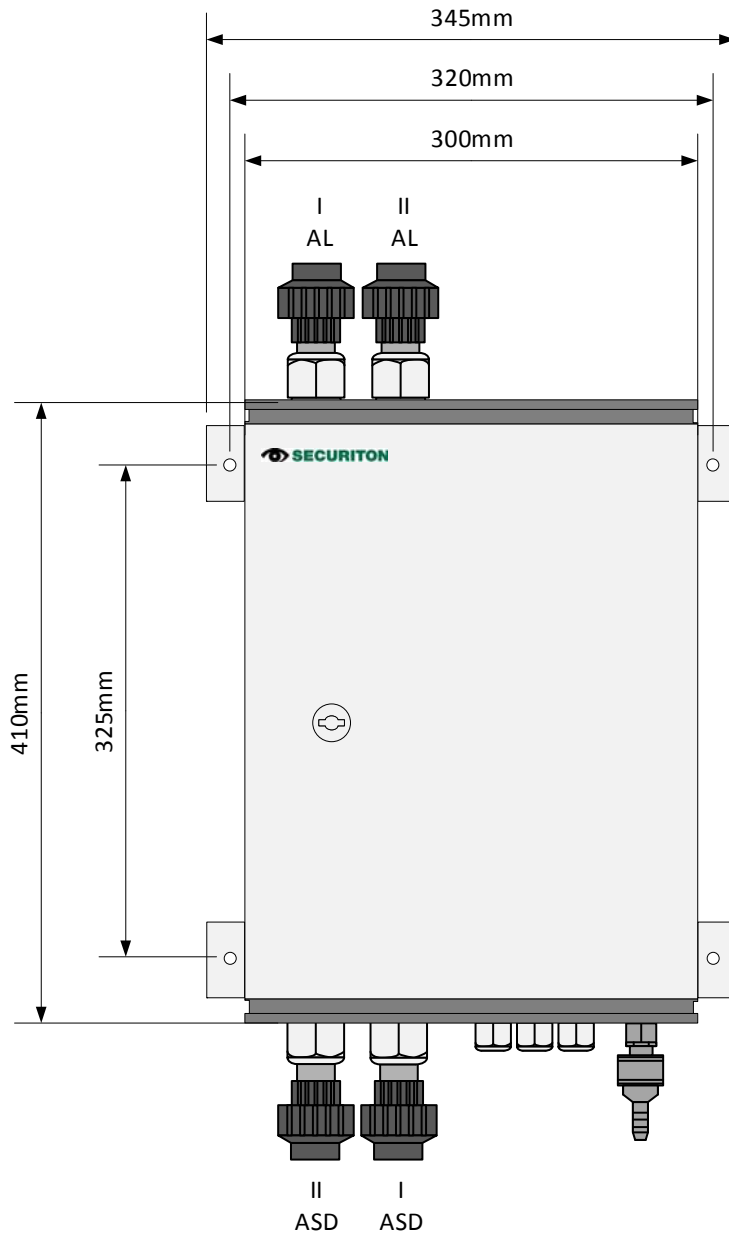

Fig. 4 Drilling plan ADB 2000

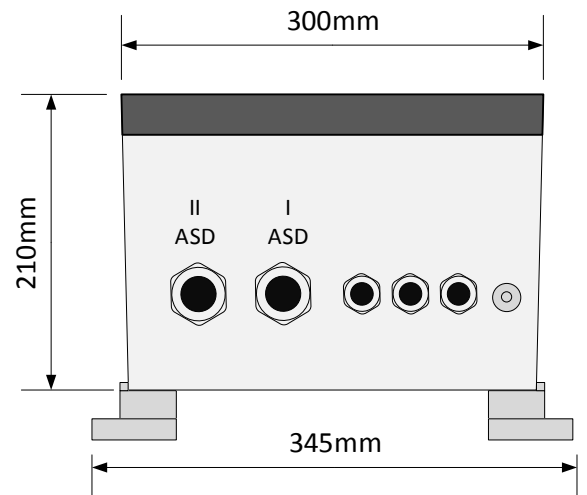

Fig. 5 Drilling plan ADB 2000

6.2 Description of connections

I ASD: Connection of the sampling pipe (channel I) between the aspirating smoke detector and the automatic blow out device ADB 2000

II ASD: Connection of the sampling pipe (channel II) between the aspirating smoke detector and the automatic blow out device ADB 2000

I AL: Connection of the sampling pipe (channel I) between the automatic blow out device and the monitoring area

II AL: Connection of the sampling pipe (channel II) between the automatic blow out device and the monitoring area

7 Mounting guidelines

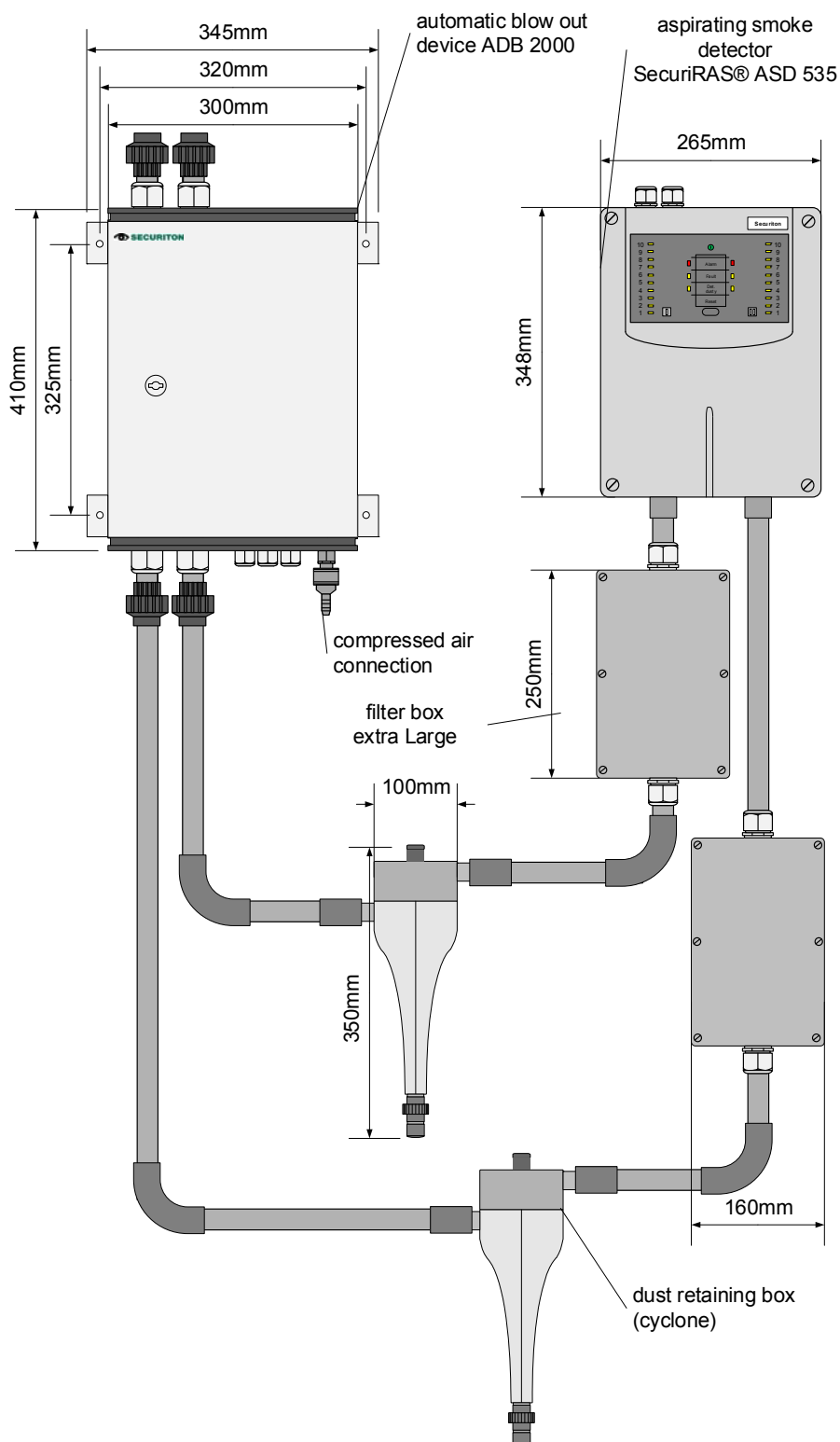

Fig. 6 Standard installation with dust retaining box (cyclone principle) and extra-large filter box



NOTICE

The minimum distance of the sampling pipe between the automatic blow out device ADB 2000 and the aspirating smoke detector SecuriRAS® ASD 53x is 2.50 m.

8 Compressed air supply

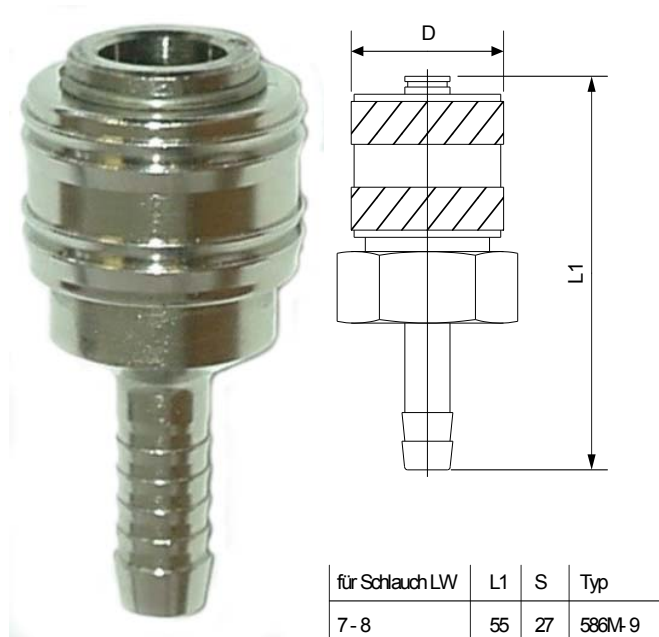

Fig. 7 Coupling socket NG 8 (for 7-8 mm pipe)

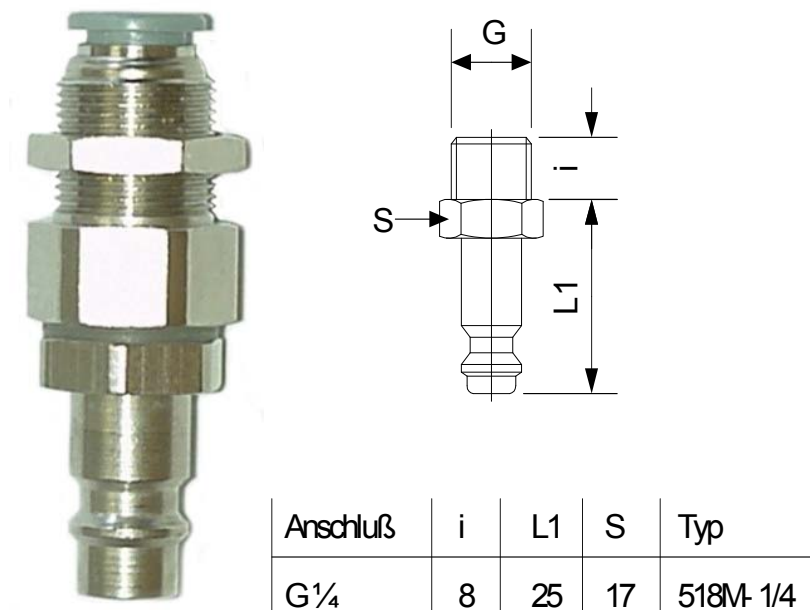

Fig. 8 Coupling plug NG 8 (G 1/4)

9 Fault transmission to CIE

So that the automatic blow out device meets the normative requirements, a failure or fault must be transmitted to the higher-level control and indicating equipment. Suitable loop modules should be used for this connection (e.g. SecuriFire / INTEGRAL).

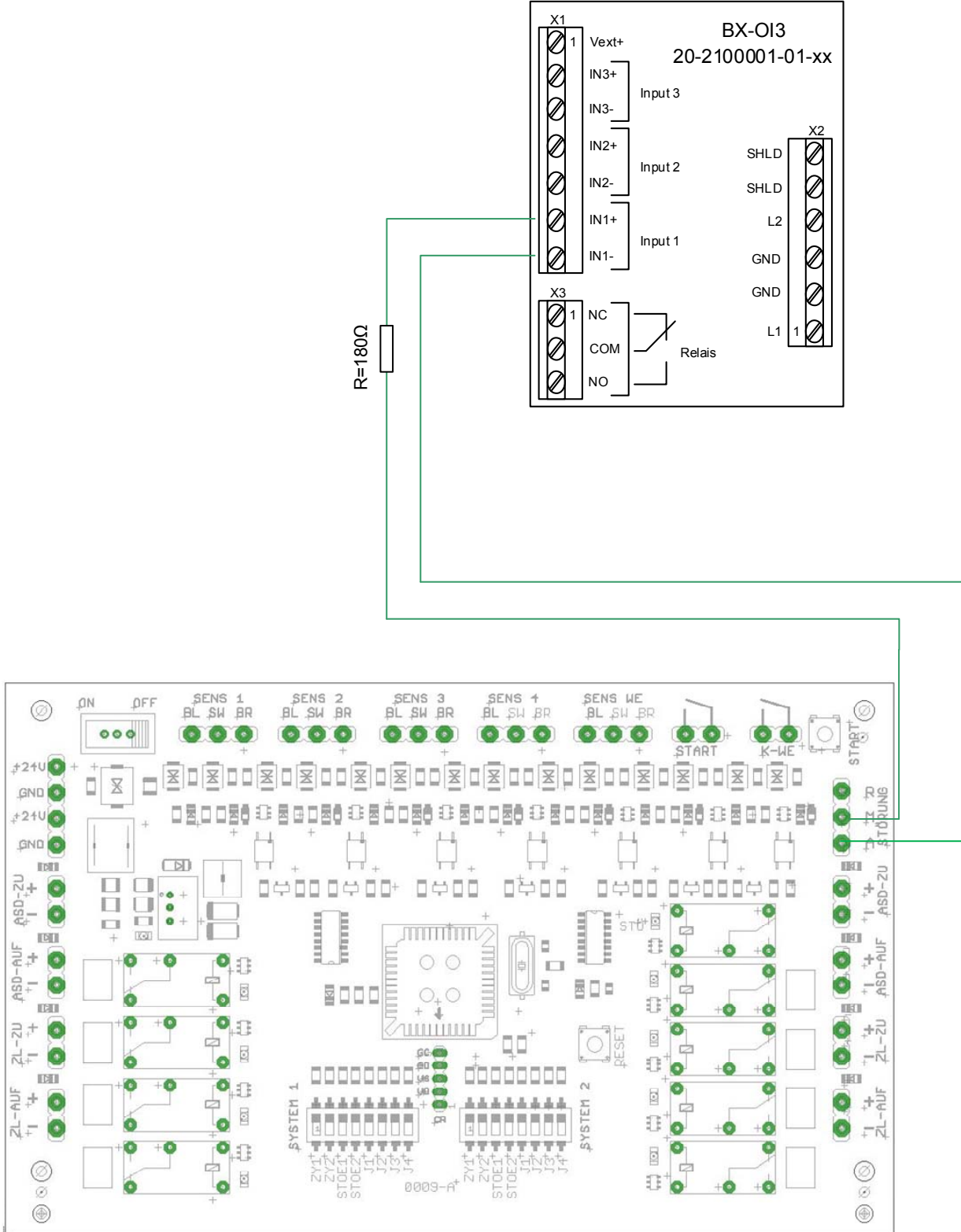

Fig. 9 Activation of fault output with loop module BX-OI3

10 Configuration automatic blow out device

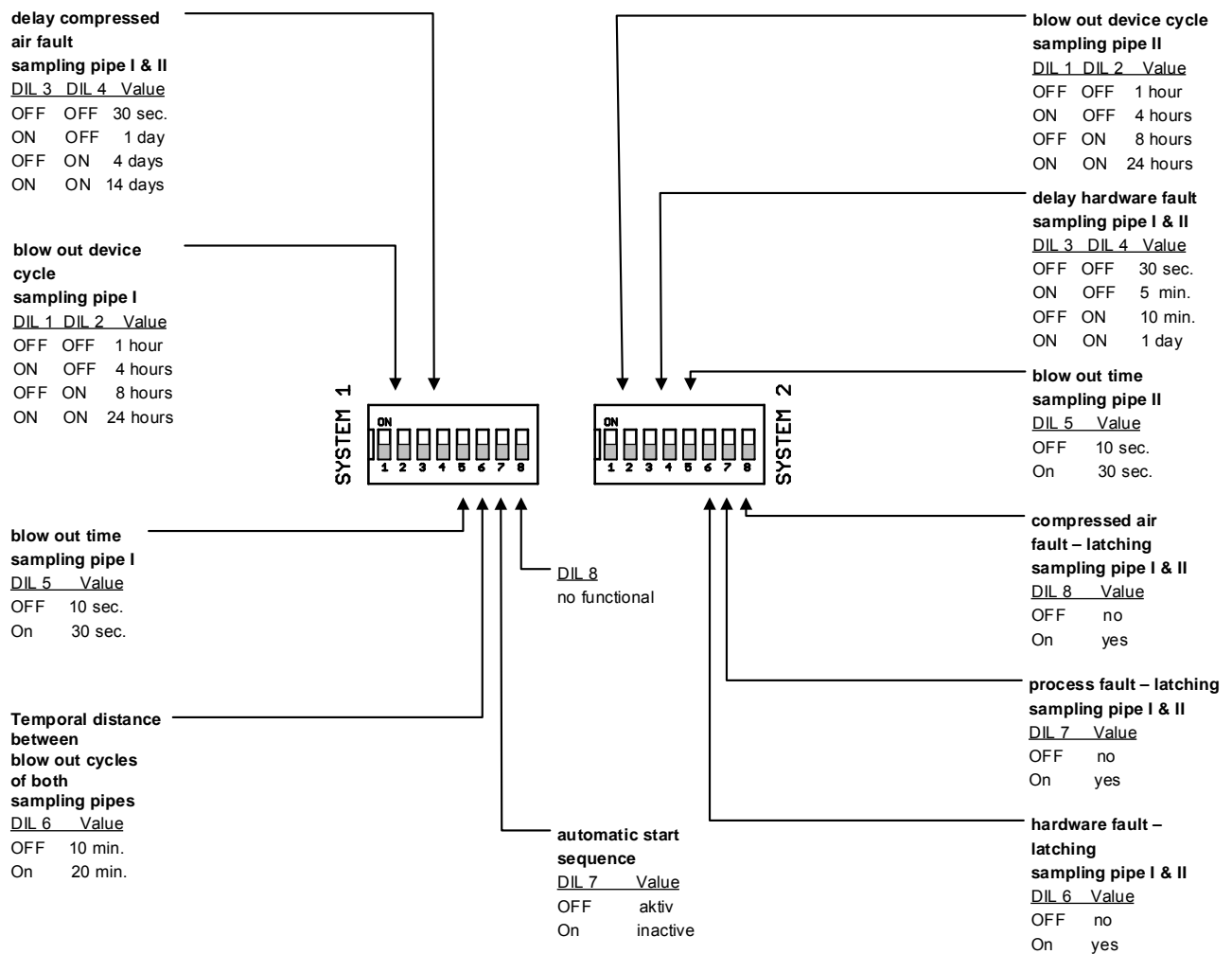

Fig. 10 DIL switch configuration

Status display of the operating and fault LED (mainboard BMB 2000):

Function / status	Operation	Failure
System off (no voltage)		
Hibernation mode	On	
Fault sampling pipe I, delay running	On	Flashing, 0.5s pulse
Fault sampling pipe II, delay running	On	Flashing, 1s pulse
Compressed air fault, delay running	On	Flashing, 0.5s pulse
Fault (general) triggered	On	On

Configuration automatic blow out device

10.1 "External input" function

For activation of the "external input", DIL switch 7 at system 1 has to be set to ON. In this case, the automatic air blow-out function is deactivated. As soon as an impulse (voltage) is received at the "external input", the air blow-out process at the sampling pipe I is carried out. The blow-out interval at sampling pipe II is afterwards applied after the time delay set at DIL switch JP 6. An additional impulse at the "external input" can respectively not be realised after only 1 hour. For example, impulse control may be realised via control and indicating equipment.

10.2 "WE contact" function

If the operator's compressed air system is deactivated for a longer period of time (eg weekends), the automatic blow out device ADB 2000 signalises a fault in the compressed air monitoring. In order to prevent this condition, the input "Contact WE" can be short-circuited during this time. This means that in general when switching off the compressed air system of the operator a contact of this system is to be provided, which acts on the input "contact WE". The automatic blow out function is deactivated in this case. When the operator's compressed air system is activated, this short circuit must be removed at the "contact WE" input so that the function of the automatic blow out device is ensured and compressed air monitoring is ensured again.



Fig. 11 Automatic blow out device ADB 2000

11 Maintenance / Service



NOTICE

Maintenance and service work on fire alarm systems are subject in part to country-specific laws and directives.

Maintenance and service work may be performed only by persons trained and authorised by the manufacturer of the aspirating smoke detector.

The technical documentation of the respective aspirating smoke detector must always be considered.



CAUTION

Work on the automatic blow out device ADB 2000 may only be carried out in a depressurised state!

Maintenance work should in principle only be carried out when the fire control systems of the aspirating smoke detector have been stopped. According to the valid regulations, the equipment should be maintained at regular intervals (quarterly), i.e. all elements influencing the function should be tested for flawless quality, cleaned and/or replaced.

12 Technical data

Features			
Supply voltage range		15 to 30	VDC
Maximum current consumption, measured in		typical 24 VDC	
ADB 2000	Rest	approx. 50	mA
	Fault I	approx. 45	mA
	Air blow-out cycle	approx. 910	mA
Fuse		2T	A
Housing protection type		54	IP
Environmental conditions			
Expanded environmental conditions:			
• Temperature range		0 to +50	°C
Maximum load bearing capacity of relay contact		50	VDC
		1	A
		30	W
Compressed air supply			
• Field of compressed air "by the building site"		Min. 4	bar
• Compressed air supplies		Coupling plug NG 8 (G 1/4); Coupling socket NG 8 (for 7-8 pipe)	
Dimensions (H x W x D)		580 x 280 x 240	mm
Weight		16.8	kg

13 Technical Data Compressor / Pressurized Air

Features			
Supply voltage		230	VAC
Power consumption		1850	W
Compressed air capacity			
• Suction capacity"		min. 290	l/minr
• Filling capacity		min. 165	l/minr
• Max. pressure		max. 10	Bar
Boiler volumes		20	l
Weight		approx. 24	kg



NOTICE

- ① Current consumption at maximum admissible voltage drop in the electrical installation (decisive value for calculation of the cable cross-section)
- ② May lead to immediate activation of the protective circuit of power supplies with overload protection (mainly at devices without emergency power supply and an output current of < 1.5 A).
- ③ After consultation of the manufacturer, lower or higher temperature ranges are also possible. Use in the condensation range is subject to consultation with the manufacturer.
- ④ Compliance with the Directive 2014/68/EU in relation to the provision of the pressure devices on the market: These Directives only start to apply for a pipe diameter with DN32. The pressure conveying pipes/sampling pipes to this automatic blow out device fixture are at a diameter of DN20, however. For this reason, this EU Directive does not need to be taken into consideration for this particular application case. However, in the event of a fault in the pressurised air, the relieve of pressure is ensured via the housing.



CAUTION

The compressed air should be provided free from oil and humidity.

14 Article numbers

Abbreviated designation		Art. no. SECURITON
Aspirating smoke detector SecuriRAS® ASD 535-1	ASD 535-1	5000623-0101
Aspirating smoke detector SecuriRAS® ASD 535-2	ASD 535-2	5000623-0102
Aspirating smoke detector SecuriRAS® ASD 535-3	ASD 535-3	5000623-0103
Aspirating smoke detector SecuriRAS® ASD 535-4	ASD 535-4	5000623-0104
Smoke sensor SSD 535-1	SSD 535-1	5000613-0101
Smoke sensor SSD 535-1-CP	SSD 535-1-CP	5000613-2201
Smoke sensor SSD 535-2	SSD 535-2	5000613-0102
Smoke sensor SSD 535-2-CP	SSD 535-2-CP	5000613-2202
Smoke sensor SSD 535-3	SSD 535-3	5000613-0103
Smoke sensor SSD 535-3-CP	SSD 535-3-CP	5000613-2203
Aspirating smoke detector SecuriRAS ASD 532	ASD 532	11-2000003-01-xx
Smoke sensor SSD 532-1	SSD 532-1	11-2000004-01-xx
Smoke sensor SSD 532-2	SSD 532-2	11-2000004-02-xx
Smoke sensor SSD 535-2	SSD 532-3	11-2000004-03-xx
Automatic blow out device ADB 1000	ADB 1000	50-0500520-01-xx
Automatic blow out device ADB 2000	ADB 2000	50-0500523-01-xx
Filter box extra-large	FBX 25	50-0500184-01-xx
Spare filter mat block (extra-large), fine stage	Filter mat extra-large	50-0500530-01-xx
Dust retaining box (cyclone principle) d=25	DRB 25 PVC	0.101166
Dirt trap box	DTB 25 PC	50-0500198-01-xx
PVC 3-way ball valve, d=25	MV 25 PVC	50-0500175-01-xx
PVC three-way ball valve with safety lever	MV 25 PVC (SH)	50-0500175-02-xx
ABS 3-way ball valve, d=25	MV 25 ABS	50-0500174-01-xx
ABS three-way ball valve with safety lever	MV 25 ABS (SH)	50-0500174-02-xx
Input/output module BX-OI3 (without housing)	BX-OI3	20-2100001-01-xx

15 List of figures

Fig. 1 Functional sequence, sampling pipe I.....	14
Fig. 2 Functional sequence, sampling pipe II.....	15
Fig. 3 Mainboard BMB 2000.....	16
Fig. 4 Drilling plan ADB 2000.....	17
Fig. 5 Drilling plan ADB 2000.....	17
Fig. 6 Standard installation with dust retaining box (cyclone principle) and extra-large filter box.....	18
Fig. 7 Coupling socket NG 8 (for 7-8 mm pipe).....	19
Fig. 8 Coupling plug NG 8 (G ¼).....	19
Fig. 9 Activation of fault output with loop module BX-OI3.....	20
Fig. 10 DIL switch configuration.....	21
Fig. 11 Automatic blow out device ADB 2000.....	22