

Product information

The ILIA Beam Smoke Detector is used for detecting smoke and fire. The ILIA Beam Smoke Detector is suitable for standard interior applications. A special dust variant (ILIA-PRO) should be used in certain harsh environments. A simple serial loop circuit connects the control unit to a maximum of eight systems for a maximum line length of 2400 m. With this control unit the detectors can be set automatically. Applications of more than 20 m in height can also be implemented. When this is the case, there must be two detection levels one above the other. Depending on the geometry of the space, it is also possible to position the beam smoke detectors diagonally or vertically in the space.



SecuriBeam ILIA

Optical Fire Detector

Design

The ILIA Beam Smoke Detector consists essentially of three components: the transmitter, the receiver, and a remote control unit. All adjustment, testing and maintenance work can be simply and reliably performed on the easily accessible control unit.

Function

An infrared beam from the transmitter passes through the monitored area, registers the information of a developing fire and reaches the receiver, which performs the analysis. The effects of a fire change the amplitude and the frequency of the light beam. Any influence is detected by the receiver and analysed. The evaluation is oriented not only to the development of the absorption (beam attenuation), as with conventional detectors of this type to date, but also includes (by means of the typical spectral frequency analysis) the typical modulation frequencies which arise when a fire starts and spreads.

The optimal evaluation of many parameters permits a reliable statement about the presence of smoke and fire. The system is extremely insensitive to disturbances caused by dust or vapour. A very slow increase of the base signal is corrected to some extent by the system (soiling compensation). If the threshold is exceeded within a given time, an alarm is triggered (very slow smouldering of, for example, cotton bales). In order to achieve optimum signal strength and stability, the system uses a unique dual transmitter (redundancy) in the overlapping area. This overlapping area of the two transmitters results in a work area of unique 12 dB. The large dispersion angle of up to 3° guarantees high reserves; this ensures trouble-free operation when building movements and operational vibrations are an issue.

Planning

On one control unit two transmitters and receivers systems can be connected in stitch

- Loop with up to 8 systems possible
- Maximal loop length 2400 m
- Main Control Unit – simple commissioning and maintenance
- Normative check-out and maintenance in accordance with EN with the remote control unit
- Monitored areas up to 3000 m²
- Monitoring length 10–200 m
- Very high sensitivity to both smoke and fire
- For demanding applications
- Special ILIA-PRO variants for very harsh environments
- Easy installation and adjustment
- Simple maintenance
- Simple alignment of the optical axes using integrated precision gears
- Soiling-resistant thanks to nano-coated lenses
- Event memory (only ILIA-PRO)
- Pre signal setting (only ILIA-PRO)

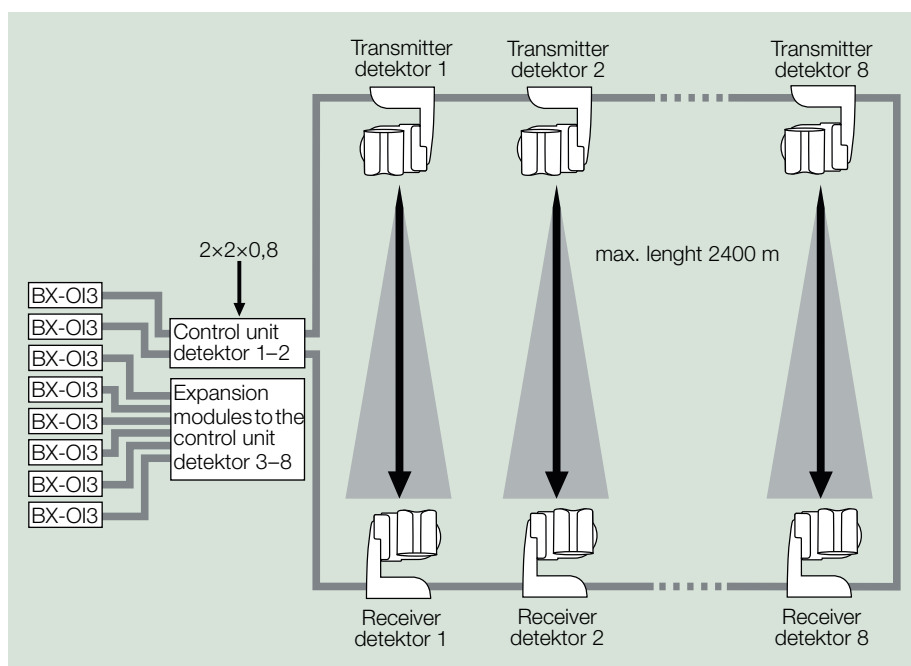

installation. With the expansion module there can be up to eight systems connected to a loop.

Thanks to the linear design with transmitter and receiver, the ILIA is used wherever structural situations prevent the installation of conventional point detectors or where the latter can no longer guarantee optimal protection.

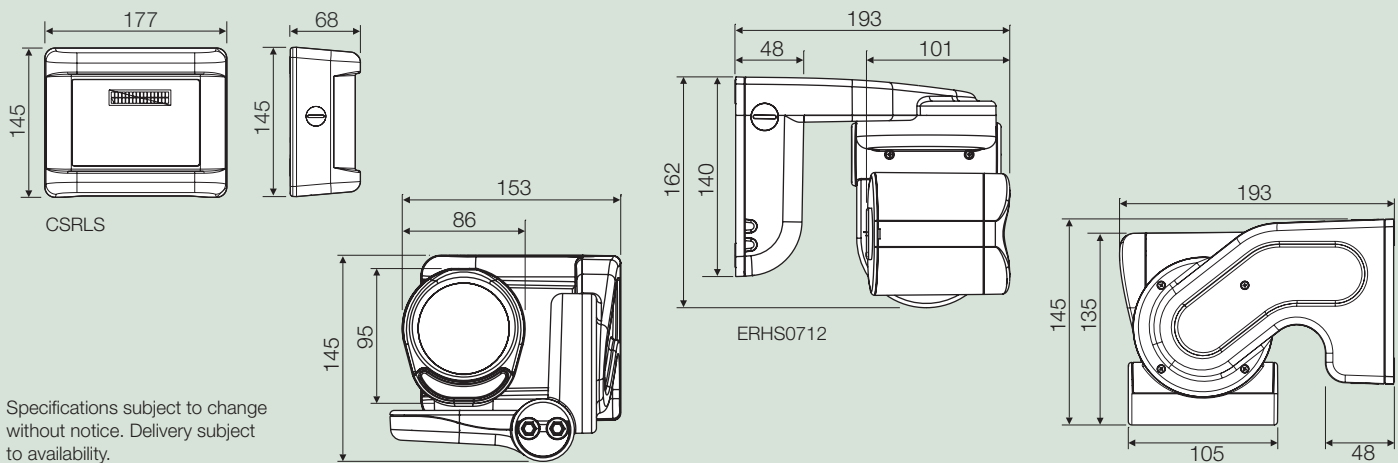

Specifications subject to change without notice. Delivery subject to availability.

Manufacturer: SETRONIC Verona Srl, 37024 Arbizzano di Negrar (VR) Italy. When in doubt, the specifications in the manufacturer's documentation are binding.

These are for example:

- Industrial plants
- Warehouses
- Archives
- Department stores
- Cinemas
- Theatres

Commissioning

When commissioning the ILIA, the following steps must be performed in the given sequence:

- Configure system version (basic settings)
- Orientate transmitter
- Orientate receiver
- Adjust aperture (if needed)
- Adjust signal strength (automatic)
- Orientation plausibility test
- Adjust signal strength (manual)
- Adjust sensitivity
- Conduct tests (alarm and fault)
- Fill out commissioning protocol
- Change password

Maintenance

The following points must be performed in the framework of maintenance:

- Check signal strength
- Transmit alarm and fault to the FACP
- Perform visual inspection

Since all checks can be performed from the ground via the control unit, the ILIA is extremely fast, easy and reliable to maintain. The nano-sealing of the panes also minimises maintenance considerably.

Technical Data

9.6 to 32 VDC	Operating voltage
162 × 145 × 193 mm	Dimensions detector (W × H × D)
177 × 145 × 68 mm	Dimensions control unit (W × H × D)
ca. 780 g	Weight detector
ca. 375 g	Weight control unit
-20 to +65 °C	Permitted ambient temperature
IP65	Protection class
G 209195	VdS approval
0786-CPD-20925	Homologation CPD
EN 54-12	Standards

Area monitored and system distances (the following limits must be complied by the arrangement of the devices)

10–200 m	Monitoring length (L)
3000 m ² (1600 m ²)	Maximum monitored area per detector according (TS 54-14)
15 m	Maximum monitoring width according to TS 54-14

Product summary

ERHS0712	ILIA Beam Smoke Detector, transmitter/receiver
ERHS0712-PRO	ILIA-PRO Beam Smoke Detector PRO, transmitter/receiver, for extremely dusty environments
ERHS0712-UL	ILIA-UL Beam Smoke Detector, transmitter/receiver
CSRLS-2	Control unit for two ILIA devices, transmitter/receiver
CSRLS-PRO	Control unit for two ILIA-PRO devices, transmitter/receiver, for extremely dusty environments
CSRLS-2-UL	Control unit for two ILIA-UL devices, transmitter/receiver
SMLS	Extension board for CSRLS and for six additional ILIA detectors