



Elegant NET 600

IT Rack Cabinet

Elegant NET IT rack series offers the permanent solution for management of Network devices and cables. The unique, flexible and effective range is the ideal solution to support the Network and server applications with its welded and durable structure.

Elegant NET IT rack networking Cabinet are intended for installation of data and telecommunication devices and their distribution systems. Mostly used for structured network cabling systems in office environments, Also to be used in computer-rooms and small or large sized data-centers. A lot of options for doors, side-and rear panels, as well as many different accessories, make the use of the enclosure very flexible.

Vertical mounting rails are adjustable throughout the entire depth of the cabinet and have very high carrying capacity with 1.5mm thickness. Silk-screen mounting rails are providing ability to count U-Marking from top to down & down to up for easy device installation.

Removable side and rear panels allow comfortable and easy access to the installed devices for maintenance from all sides of the cabinet. For active cooling, it is possible to install an optional fan-unit into the roof and/or floor. Due to flat-pack construction it is possible to bring them also into places with difficult access, basement or attic, in the narrow entrance or stairs.

We are responding the needs of users with choice of 9 different height dimensions.

Height : 12U-16U-20U-22U-26U-32U-36U-42U-45U-47U
 Width : 600mm
 Depth: 600mm & 800mm & 1000mm

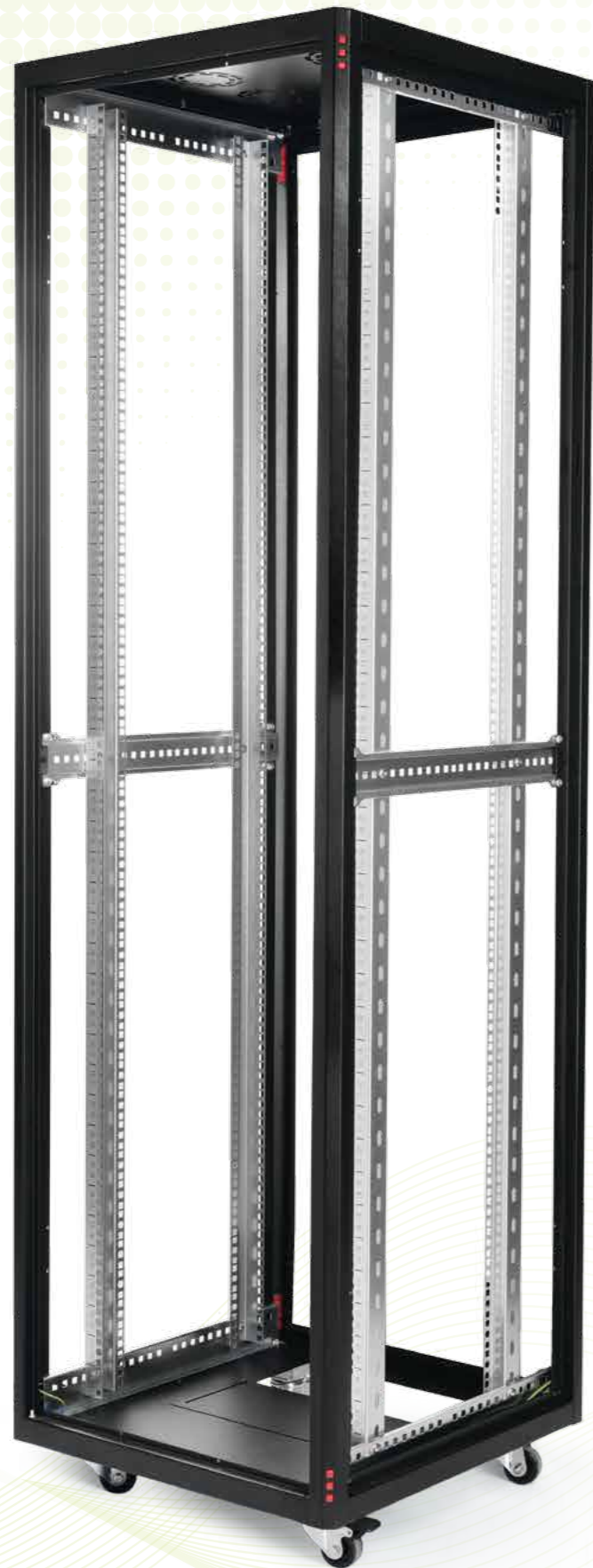

Elegant NET 600 IT Rack Cabinet

Quick-change fan tray allows accessibility without removing the cables or active devices from the rack in case of any maintenance or replacement needs.

Elegant NET ; Top cover has been designed for ventilation module which can be detached by removing 4 pcs screws from the top in case of maintenance or replacement needs.

Protect your device against overheating by choosing the right fan module.

We offer a wide product range of ventilation units with the different fan modules.

On/Off switch Fan modules Analog or digital
Thermostat control unit Fan modules



Professional Network Cabinets

Elegant NET
IT-Rack Cabinet



M-joint cable entry panels located on the top cover designed for easy cabling and High-density cabling.

Dimensions w: 300 - D: 56 mm



Sliding cable entry panels located on the bottom plates has been designed for easy cabling and High-density cabling by using sliding cable entry panels with the dimensions w: 300 - D: 125 mm



Vertical mounting rails are adjustable throughout the entire depth of the cabinet and have very high carrying capacity with 1.5mm thickness, Silk-screen mounting rails are providing ability to count U- Marking from top to down & down to up for easy device installation



Castors

Castor and/or levelling feet could be mounted on to rack.

Elegant NET 600

IT Rack Cabinet

Door options / W: 600 mm

The front door is designed to provide security with lock mechanism and decorative view together, full-length smoked and shatterproof glass door deployed in metal frame, easily rotated to the left

or right directions by special spring hinge, in case of needs 3 points and single point locking systems are available depends on customer requirements.

Easily removable side panels complete with Barrel lock & Sliding latch locks

RAL 9005-Black (Standard Colour)
RAL 7035-Light Gray (Optional)



elegant net cabinets

%80 Curved Perforated Metal Door-Single



%63 Curved Perforated Metal Door-Single



Flat Metal Door-Single



Tempered Glass Door-Single



%80 Perforated Metal Door-Double



%63 Perforated Metal Door-Double



Flat Metal Door-Single



Technical Drawing
W: 600 mm d: 800 mm

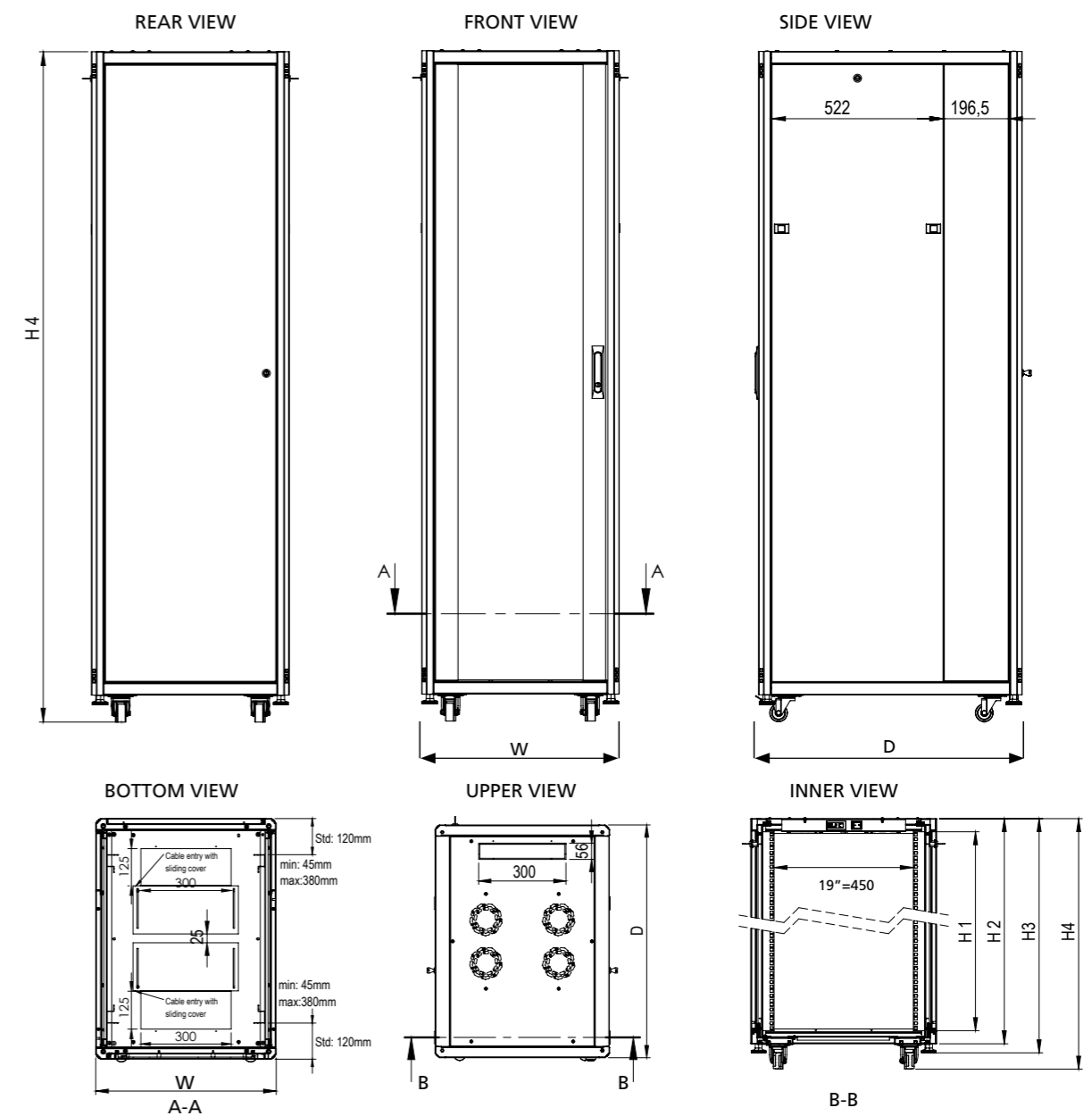
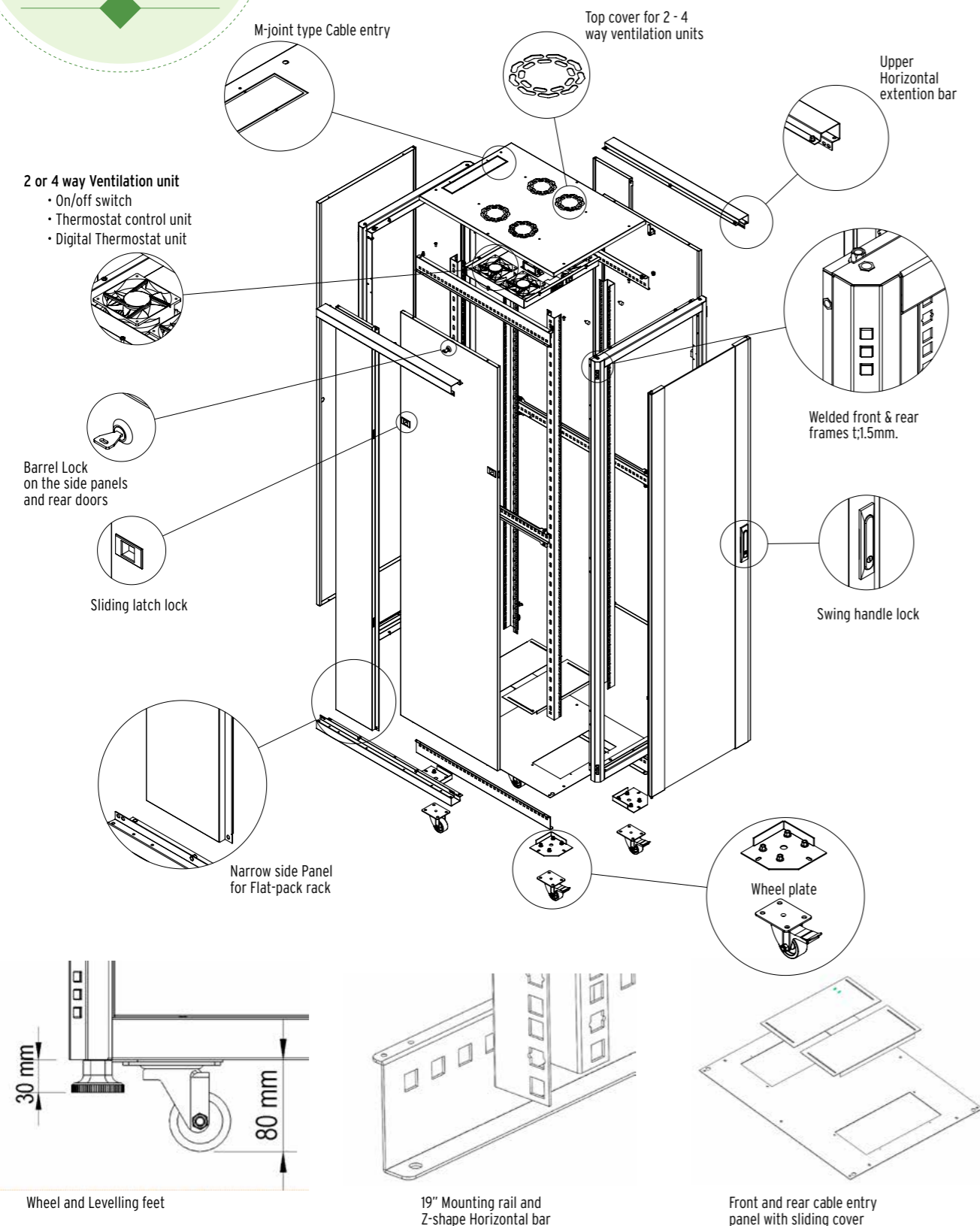

600 x 800 mm FLOOR STANDING ELEGANT NET

Product Code	Product Description	Out Width (W) (mm)	Out Depth (D) (mm)	H:1 Inner Height (mm)	H:2 Out Height without feet & wheel set (mm)	H:3 Out Height with levelling feet (mm)	H:4 Out Height with wheel set (mm)
ELGN 12U 6080 CC 111	Elegant NET 19" 12U W=600 mm D=800 mm	600	800	536,6	621,5	651,5	701,5
ELGN 16U 6080 CC 111	Elegant NET 19" 16U W=600 mm D=800 mm	600	800	714,4	799,3	829,3	879,3
ELGN 20U 6080 CC 111	Elegant NET 19" 20U W=600 mm D=800 mm	600	800	892,2	977,1	1007,1	1057,1
ELGN 22U 6080 CC 111	Elegant NET 19" 22U W=600 mm D=800 mm	600	800	981,1	1066	1096	1146
ELGN 26U 6080 CC 111	Elegant NET 19" 26U W=600 mm D=800 mm	600	800	1158,9	1243,8	1273,8	1323,8
ELGN 32U 6080 CC 111	Elegant NET 19" 32U W=600 mm D=800 mm	600	800	1425,6	1510,5	1540,5	1590,5
ELGN 36U 6080 CC 111	Elegant NET 19" 36U W=600 mm D=800 mm	600	800	1603,4	1688,3	1718,3	1768,3
ELGN 42U 6080 CC 111	Elegant NET 19" 42U W=600 mm D=800 mm	600	800	1870,1	1955	1985	2035
ELGN 45U 6080 CC 111	Elegant NET 19" 45U W=600 mm D=800 mm	600	800	2003,45	2088,35	2118,35	2168,35
ELGN 47U 6080 CC 111	Elegant NET 19" 47U W=600 mm D=800 mm	600	800	2092,35	2177,25	2207,25	2257,25

**CC Means=Color Code, BL=Rall 9005 Black, LG=Rall 7035 Light Gray

W600
Curved Perforated

PERFORATED FRONT VIEW



PERFORATED REAR VIEW

W600
Splited Perforated



**We believe
You deserve the
best infrastructure
solutions**



Elegant Net Provides Economic and Durable Solutions

Benefits Of The Excellent Cabling

- Maximised Cabling Paths Or Optized System Performance
- Proper Cabling
- Easy Cabletracing
- Easy Cable Replacing
- Easily Removing Hardware
- Increasing The Airflow Ability Against The Overheating Devices Because Of Wrong Located Cable Bundles.